

S2 Evo

Translation of the original instructions



Table of contents

Table of contents.....	2
Description S2 Evo	4
Supplier Declaration.....	5
General information	7
Intended use.....	7
Liability provisions	7
Safety precautions	7
Warranty provisions	7
Labelling.....	7
Disposal	7
Transport and handling.....	7
Storage	7
Safety information	8
Safety symbols.....	8
General	8
Risks on the equipment (residual risks)	8
Operation.....	8
Service/maintenance:.....	8
Safety signs:	9
Installation	10
Mounting the unit	10
Mounting the pipe connections	10
Start-up of operations	10
Installation kits.....	10
Dimensional drawing	12
Main elements.....	14
Main elements list.....	15
Pneumatic diagram	16
Technical specifications	17
Description of functions.....	18
Operating elements.....	18
Maintenance	20
Non-return valves	20
Suction hose and suction filter.....	20
Injector	20
Service kits	20
Service quick guides	21
Depressurising the satellite unit before servicing.....	21
Removing the valve.....	22
Air non-return valves.....	23
Air check valves, separate outlet.....	24
Chemical non-return valve main valve	25
Chemical non-return valve, separate outlet	26
Non-return valve.....	27
Replacing the O-rings, function selector axle.	28
Inserting the valve after servicing.	30
Restarting after servicing	31
Quick operations guide	32
Adjusting the chemical concentration, main valve	32
Adjust the chemical concentration, separate outlet	33

Concentration table	34
Adjustment of airflow/foam volume.....	34
Mode F D	35
Mode F F.....	36
Mode separate D	37
Mode separate F	38
Flowdiagram	39
Mode F D & F F.....	39
Mode F D & F F + F or D	40
Troubleshooting	41
Manual revision	42

Description S2 Evo

The S2 Evo satellite is made for manual cleaning in the food and beverage industry.
The satellite must be connected to pressurised water, see specifications.

The satellite has a built-in injector for mixing water and detergent.

The satellite makes it possible to rinse surfaces and apply detergent to surfaces.
If a foaming detergent is to be used for cleaning, the satellite allows compressed air to be added to the detergent.

All components in contact with concentrated detergent may consist of AISI 316, Viton, PVC
or a combination of these materials.

It is the user's responsibility to ensure that the detergent is compatible with these materials.

Supplier Declaration

Manufacturer:

System Cleaners A/S
Halkjærvej 17
DK-9200 Aalborg SV
Denmark

Product series: Satellite S2 Evo

Year of manufacture: 2026

Description: The satellite unit is made for manual cleaning in the food and beverage industry.

Application and scope: The satellite must be supplied with pressurised water and compressed air.

When the satellite unit is connected to a supply source, the integrator is responsible for the CE marking of the complete system.

Technical background: We, System Cleaners A/S, have used the relevant technical standards in the design and construction of the unit.

Standards:

EN ISO 12100:2011 - Risk assessment and risk reduction
EN ISO 13849-2:2014 - Part 2: Validation
EN ISO 13849-1:2023 – Part 1: General principles for design.
EN ISO 4414:2010 - General rules and safety requirements

The use of the above standards does not constitute a declaration of conformity with EU directives and does not infer the unit is CE marked.

Responsible for the technical file:



Hanne Søberg Mouridsen
Documentation engineer
Aalborg SV, 14/04/2026



Member of AxFlow Group

General information

For safety during installation and subsequent use, it is extremely important that the manual is followed carefully. Please keep this user manual in a place where it is available at all times and hand it over to the person responsible for this product. If the user manual is lost, you are welcome to request a new one from your dealer. If there is any doubt about the content of the instructions, contact the dealer for clarification.

Intended use

The System Cleaners unit is designed for use with water and detergents only.

- Rinse with water.
- Application of foam.
- Application of disinfectant.

Any other use besides this is considered inappropriate and a deviation from the provisions, and may lead to dangerous situations.

System Cleaners A/S is not liable for consequential damages caused in this respect.

Intended use means:

- The instructions, regulations and recommendations given in the user manual for the satellite unit.
- Compliance with the prescribed inspection and maintenance intervals.
- Correct maintenance of the unit to keep it in good working order.
- Compliance with the prescribed environmental and operating conditions.
- Use of a detergent compatible with the materials in the unit.

Intended use also includes compliance with all the information provided in this user manual. This applies in particular to the specified safety instructions.

Liability provisions

It is the responsibility of the individual user to handle and use the satellite unit in a safe manner. It is therefore extremely important that this user manual is available to the sanitation worker.

Safety precautions

The satellite unit is designed in accordance with the generally accepted technical rules and regulations as well as working environment and accident prevention regulations. Nevertheless, risks may arise during use that could cause physical harm to the user or third parties or affect the satellite or other equipment. The unit must therefore be in optimal technical condition before use and may only be used in accordance with its intended use and in compliance with the safety regulations and operating instructions. In particular, faults that may affect safety must be rectified immediately.

Warranty provisions

Please refer to the current sales and delivery conditions.

Labelling

The satellite unit is supplied with a type plate with technical data. The type plate is located on a fixed part of the unit.

Disposal

This unit and its parts must be disposed of in an environmentally sound manner in accordance with local legislation.

Use the public or private recycling stations.

If the aforementioned is not possible, please contact your nearest System Cleaners representative.

Transport and handling

Care must be taken when lifting the unit due to its weight and sharp edges.

Use cut-resistant gloves when handling the satellite unit.





Storage

When storing the unit, the ambient temperature must be kept above freezing point.

After long-term storage, the unit must be rinsed before it is used in production.

Safety information

Safety symbols

	General warning. Read the documentation before using the satellite unit. Read the documentation before servicing the unit.
	There may be hot surfaces. Take special care when servicing the satellite unit.
	Goggles must be worn when operating the satellite unit. Goggles must be worn when servicing the unit.
	Gloves must be worn when operating the satellite unit. Gloves must be worn when servicing the unit. Wear cut-resistant gloves when servicing.

General

This satellite unit may only be operated by trained professionals or persons who have been properly instructed in how to operate it.

Service may only be carried out by trained professionals or maintenance personnel who have been properly instructed in how to service it.

Never point the outlet nozzle at other people or electrical installations.

Risks on the unit (residual risks)

Operation

- Always wear safety goggles, gloves and appropriate work clothing when using the satellite unit (PPE).
- Risk of getting chemicals in the eyes (HIGH RISK).
- Risk of getting high-pressure water in the eyes (HIGH RISK).
- Risk of getting chemicals on the skin (HIGH RISK).
- Risk of scalding (HIGH RISK).
- It is the user's/fitter's responsibility to ensure that water is not used at temperatures above 70 °C.

The lid must always be firmly screwed on.

Risk of high-pressure water/chemicals in the event of failure (MEDIUM RISK).

Service/maintenance:

- Always wear safety goggles, cut-resistant gloves and appropriate work clothing when servicing the satellite unit (PPE).
- Risk of getting chemicals in the eyes (HIGH RISK).
- Risk of getting high-pressure water in the eyes (HIGH RISK).
- Risk of getting chemicals on the skin (HIGH RISK).
- Risk of cutting/striking yourself (HIGH RISK).

During servicing: supply to the satellite unit is closed by a ball valve. Air and water to the unit is closed off.

The unit must be depressurised before servicing, as there is a risk from high-pressure water/chemicals (HIGH RISK).

Safety signs:

The following pictograms are placed on the equipment (size is 65x68 mm).
Scale displayed (1:1).



Installation

Mounting the unit

- The wall material should be of a stable quality that can support the weight of the unit.
- Mounting must be performed with the screws and plugs supplied.
- Drill holes for the unit's mounting holes according to the dimensional drawing.
- For servicing, we recommend that you allow 1m free space around the unit.

Mounting the pipe connections

In general, pipe connections must be made in accordance with local regulations.

It is the fitter's responsibility to ensure compliance with applicable legislation.

- All pipes must be rinsed through before they are connected to the satellite unit.
- Lockable shut-off valves must be fitted to all pipe connections and the air connection.
- The fitter must comply with any local requirements regarding pipe interrupters, if any exist.
- We recommend that you select pipe sizes that keep the flow velocity below 3 m/s. This normally provides an acceptable pressure loss and low flow noise.
- It must be ensured that the water temperature does not exceed 70 °C.

Start-up of operations

The satellite unit must be rinsed through before the unit is taken into use or after servicing.

Installation kits

Item number	Installation kit
96-011000	S1 Evo

Dimensional drawing

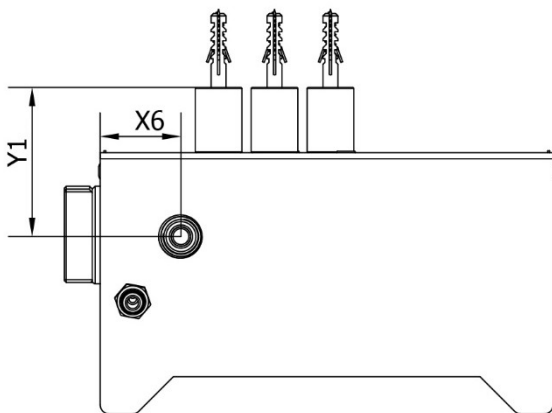
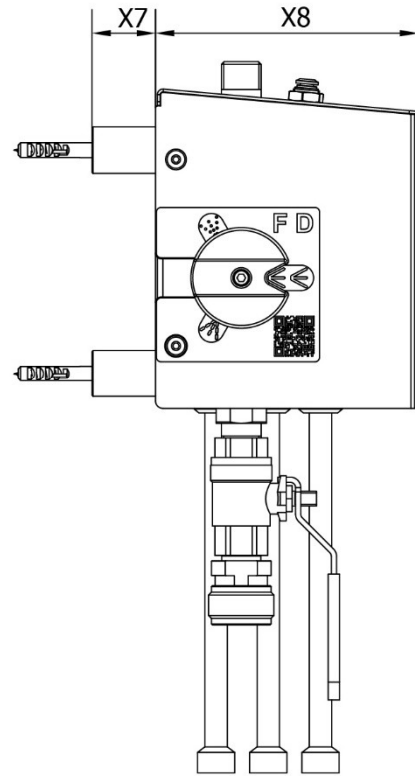
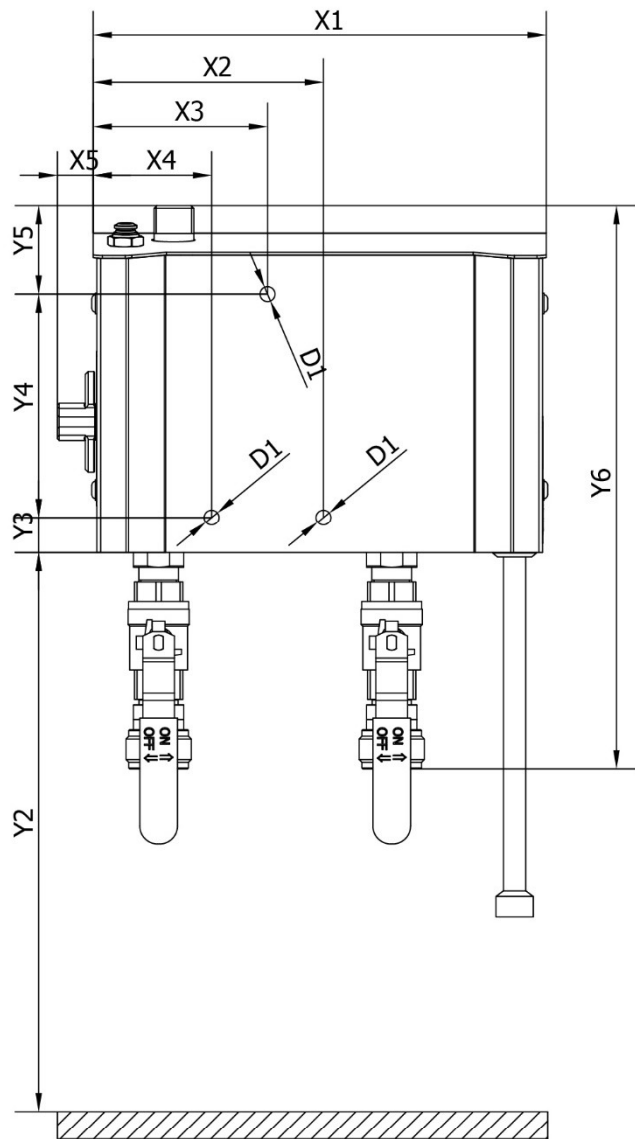

Item	Millimetres	Inches
X1	243	9 ⁹ / ₁₆
X2	123,5	4 ²⁷ / ₃₂
X3	93,5	3 ¹¹ / ₁₆
X4	63,5	2 ¹ / ₂
X5	19	³ / ₄
X6	43	1 ¹¹ / ₁₆
X7	34	1 ¹¹ / ₃₂
X8	141	5 ³⁵ / ₆₄
Y1	80	3 ⁵ / ₃₂
Y2	1200	47 ¹ / ₄
Y3	19	³ / ₄
Y4	120	4 ²³ / ₃₂
Y5	47,5	1 ⁷ / ₈
Y6	303	11 ⁵⁹ / ₆₄
D1	Ø8	⁵ / ₁₆

Main elements

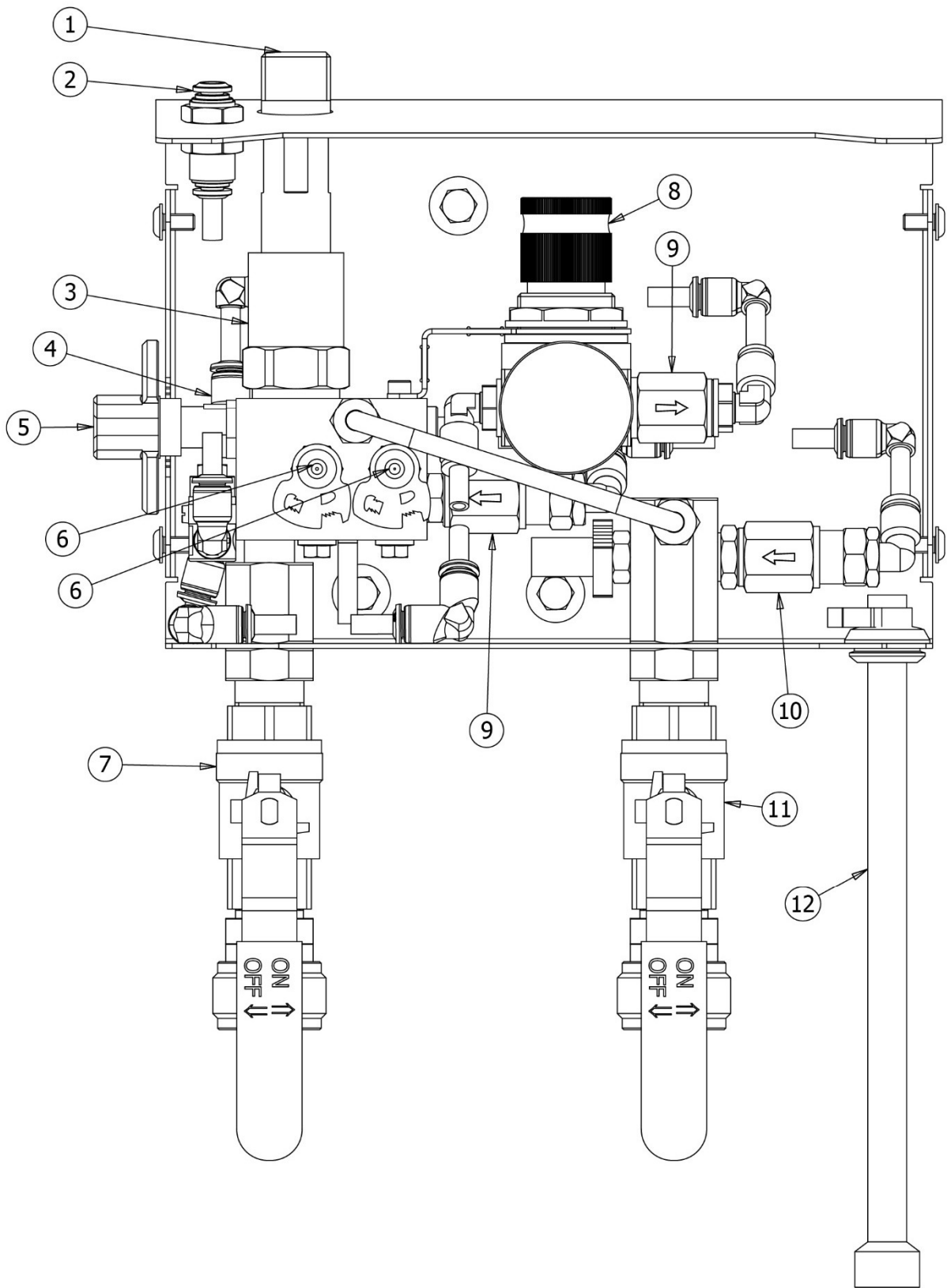

Main elements list

Item	Description
1	Inlet, water
2	Inlet, air
3	Non-return valve, water
4	Main valve
5	Function selector
6	Non-return valve, chemical and chemical dosing tip
7	Outlet, water
8	Compressed air regulator
9	Non-return valves, air main valve
10	Non-return valve, air separate outlet*
11	Outlet, water separate outlet*
12	Chemical suction hose

*Model dependent

Pneumatic diagram

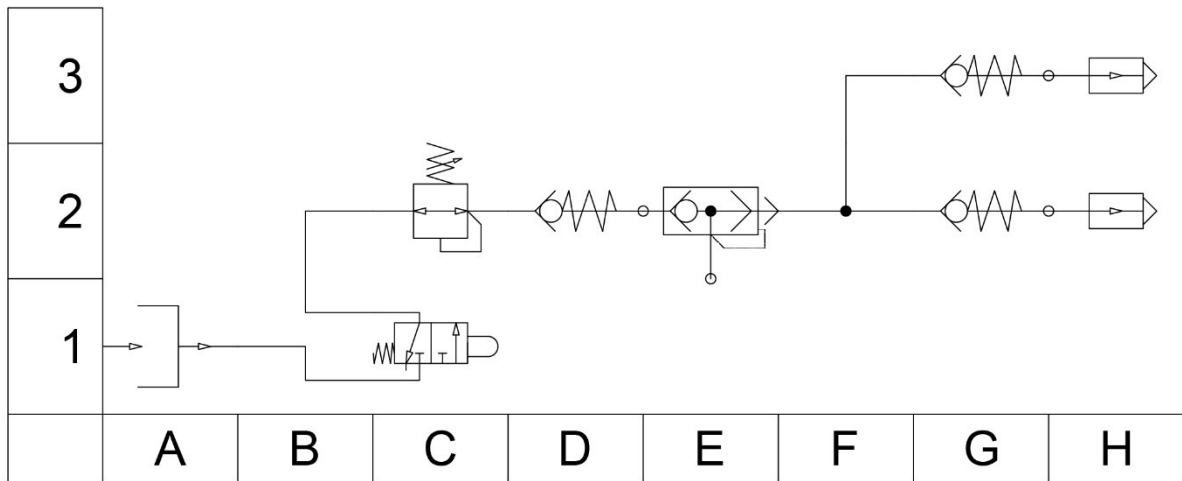

Row	Column	Description
1	A	Air connection
1	C	Air valve
2	C	Air pressure regulator
2	D	Non-return valve on air pressure regulator
2	E	Backflow preventer valve
2	G	Non-return valve on air nozzle
2	H	Air nozzle
3	G	Non-return valve (Only separate mode F)
3	H	Air nozzle (Only separate mode F)

Technical specifications

	S2 Evo
Installation	
Ambient temperature	3-40 °C // 37-104 °F
Water supply	
Connection	1/2" BSPT // 1/2" NPT
Inlet pressure, 3-8 bar version	3-8 bar // 43-116 psi
Inlet pressure, 15-25 bar version	15-25 bar // 217-362 psi
Temperature	3-70 °C / 37-160 °F
Filtration rating	≤800 µm
Recommended minimum supply quantity	4 m ³ /h // 16 US gal/min
Water outlet	
Connection	SC coupling
Maximum flow at 20 bar	45 litres/min // 12 US gal/min
Maximum flow at 8 bar	30 litres/min // 8 gal/min
Air supply	
Connection	Ø6 // ¼" NPT
Pressure range	5-10 bar // 73-145 psi
Compressed air quality	DIN ISO 8573-1, class 4
Minimum supply quantity	150 litres/min // 5.3 cfm
Concentrated product	
Concentration* 3-8 bar version	0,7-15%
Concentration* 15-25 bar version	0,7-9%
General	
Width x height x depth	265 x 345 x 175 mm // 11 x 14 x 7 inches
Maximum weight	5,5 kg // 12 lbs
Noise level	<70 dB

*Depending on product viscosity, back pressure etc. test performed with water

Description of functions
Operating elements

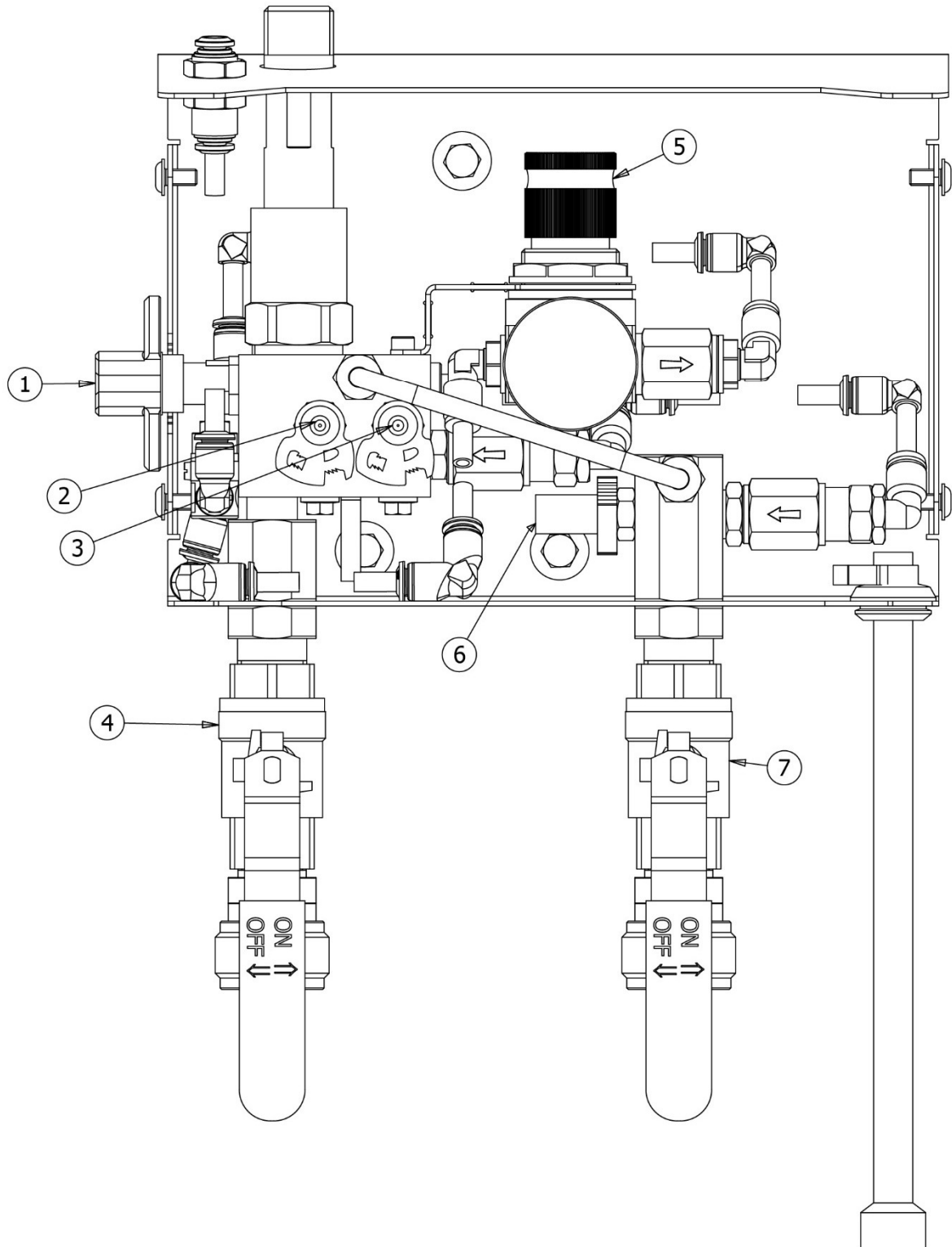

Item	Description
1	Function selector
2	Chemical limiter
3	Chemical limiter
4	Outlet, main valve
5	Air pressure regulator
6	Chemical limiter, separate outlet*
7	Outlet, separate outlet*

*Model dependent

Item 1 – Function selector

The function selector is used to select a mode. There are three positions.

Green symbol = Rinse.

Blue symbol = Foam application.

Red symbol = Foam application*

Yellow symbol = Disinfectant application*

*Model dependent

Item 2 - Chemical limiter (Blue symbol on function selector)

The chemical limiter is used to limit how much the chemical injector can suck in.

The chemical limiter can be replaced to ensure the correct chemical dosage.

Item 3 - Chemical limiter (Red or yellow symbol on function selector) *

The chemical limiter is used to limit how much the chemical injector can suck in.

The chemical limiter can be replaced to ensure the correct chemical dosage.

*Model dependent

Item 4 - Outlet valve main valve

The valve is used to close the outlet on the satellite after use.

The valve must also be closed before changing the outlet hose.

Item 5 – Air pressure regulator

The air pressure regulator is used to increase or decrease the quantity of air that is added when the function selector is set to foam mode.

Item 6 - Chemical limiter separate outlet*

The chemical limiter is used to limit how much the chemical injector can suck in.

The chemical limiter can be replaced to ensure the correct chemical dosage.

*Model dependent

Item 7 - Outlet valve separate outlet*

The valve is used to close the outlet on the satellite after use.

The valve must also be closed before changing the outlet hose.

*Model dependent

Maintenance

Non-return valves

Both water, chemical and air non-return valves should be checked weekly.

The water non-return valve protects the fresh water supply against the backflow of chemicals from the satellite unit.

There are two non-return valves in the air system. Between the non-return valves is a backflow preventer valve. The purpose is to protect the air supply.

There is a non-return valve on each chemical inlet. The purpose is to prevent water from entering the chemical container.

It is recommended that you service/replace all non-return valves once a year. Depending on use, it may be necessary to change them more frequently.

Suction hose and suction filter

Both filter and hose should be inspected weekly.

We recommend that you change both filter and hose every year.

Injector

The water nozzle may become clogged from lime buildup. It should be checked once a month. Descale the water nozzle if it is clogged.

Service kits

Annual service kit 2 x Chemical, 96-010410

Annual service kit 3 x Chemical, 96-010411

Service kit chemical non-return valve, 96-011100

Service kit water non-return valve, 96-010101



Service quick guides

Depressurising the satellite unit before servicing.

For safety reasons, this must be done before disassembling internal components.

1. Disconnect the fluid and air supplies.

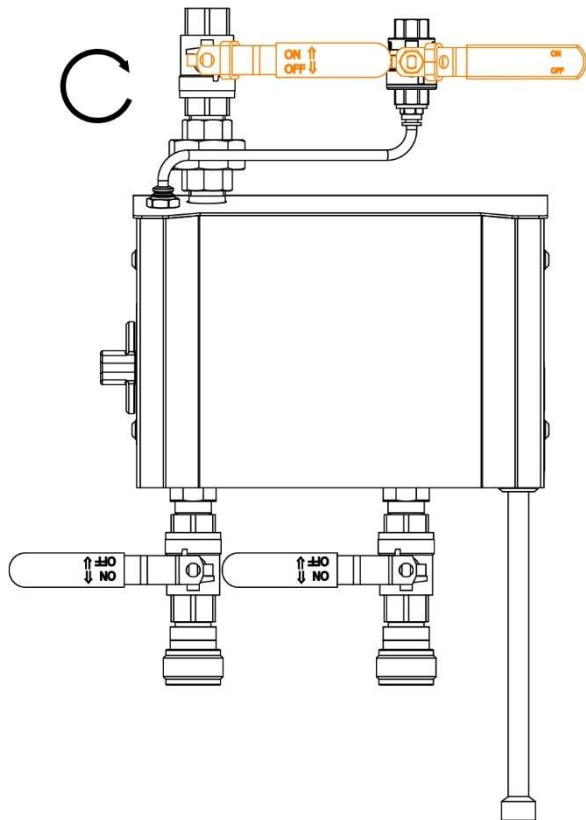

2. Open the outlet valve.

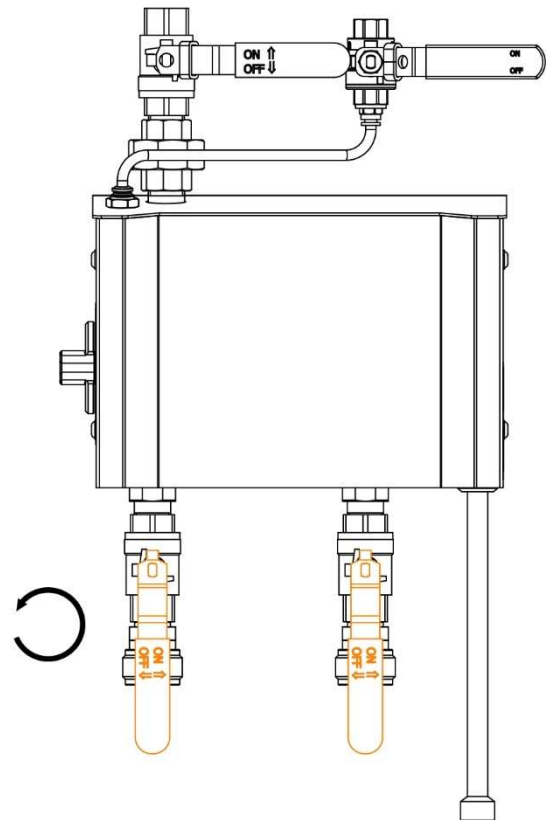

3. Set the function selector to foam.

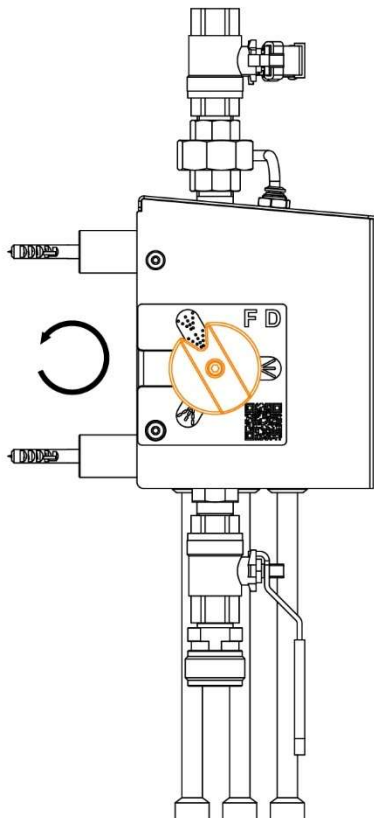

Removing the valve

1. Remove the screws on the side of the cabinet.

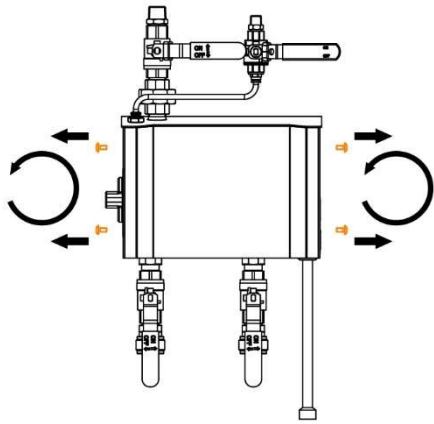

2. Remove the lid.

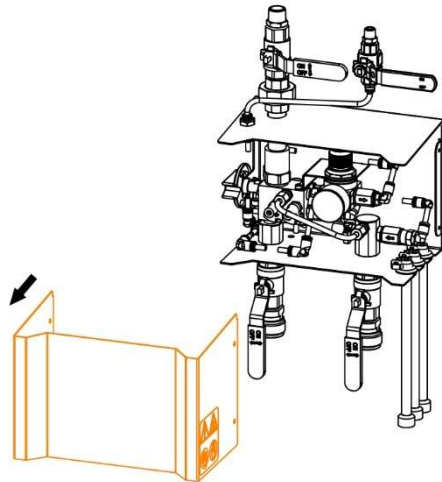

3. Remove the outlet valve.

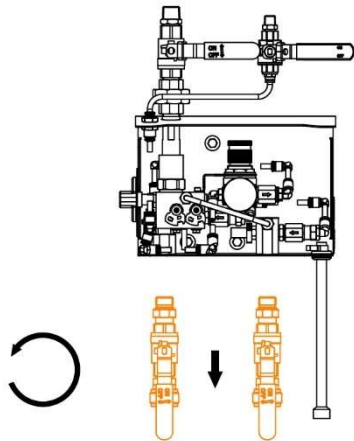

4. Loosen the union nut around the non-return valve.

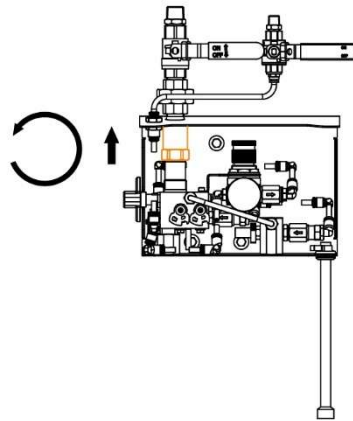

5. Remove the non-return valve.

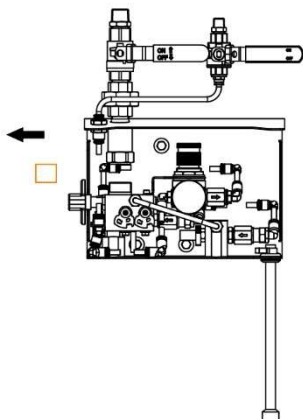

6. Remove the valve assembly.

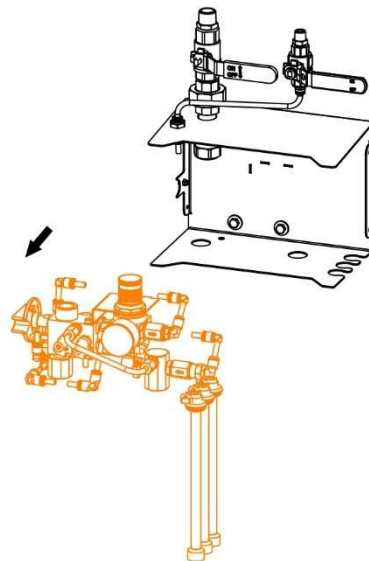

Air non-return valves

1. Remove the air fitting.

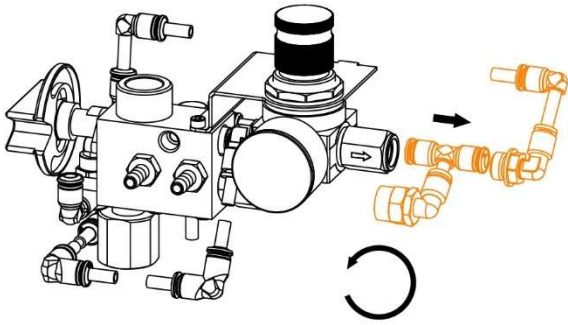

2. Remove the non-return valves.

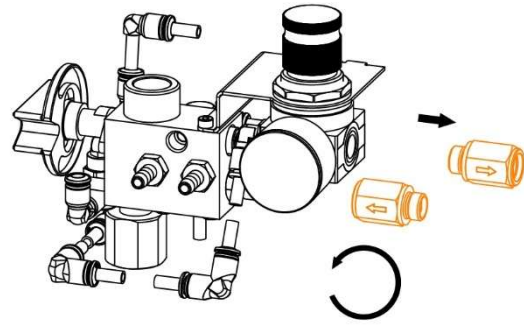

3. Remove the air fittings.

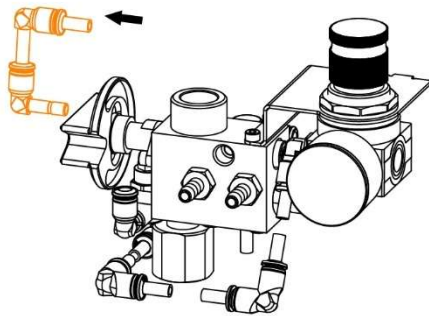

4. Remove the backflow preventer.

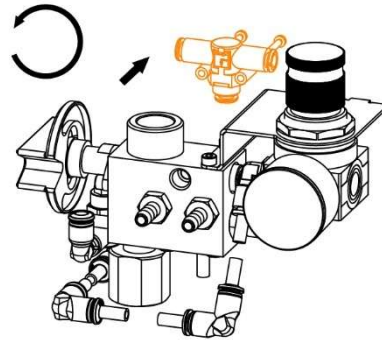

5. Fit the new backflow preventer.

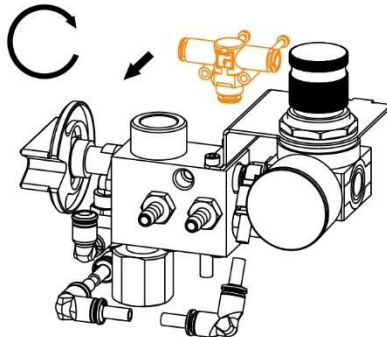

6. Fit the air fittings.

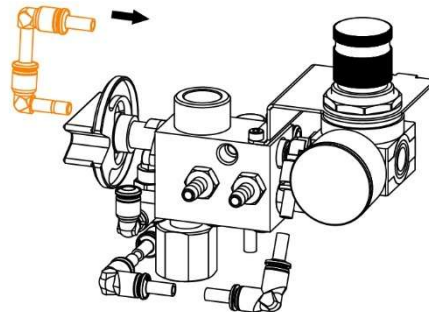

7. Fit the new non-return valves.

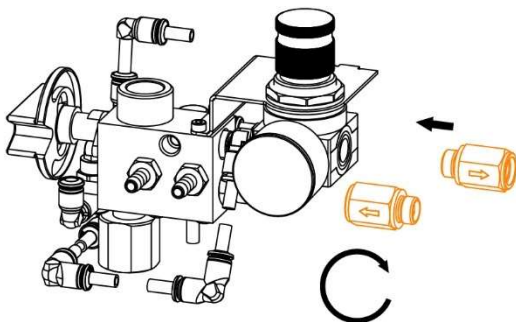

8. Fit the air fitting.

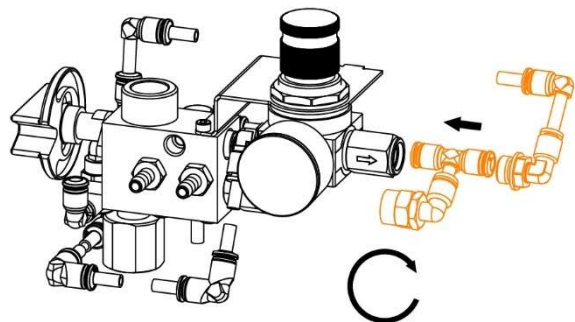

Air check valves, separate outlet

1. Remove the air fitting.

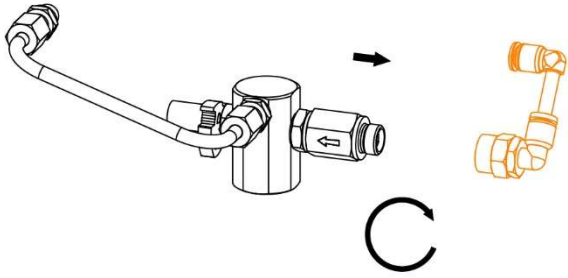

2. Remove the non-return valves.

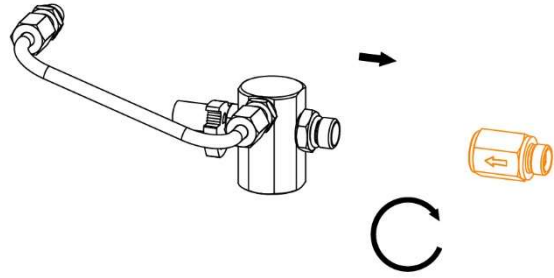

3. Fit the new non-return valve.

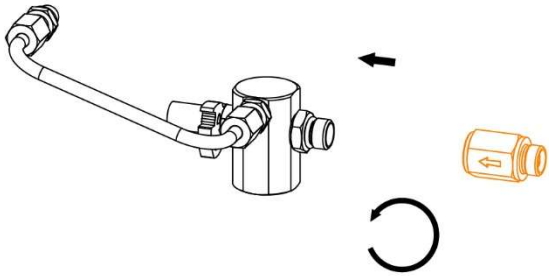

4. Fit the air fittings.

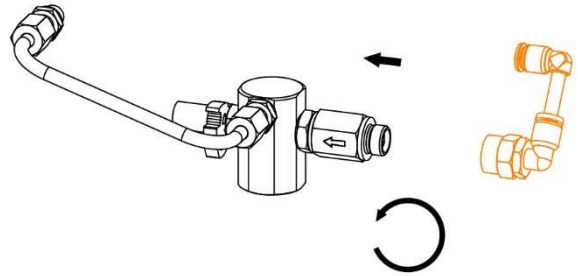

Chemical non-return valve main valve

1. Remove the hose clamp and suction hose.

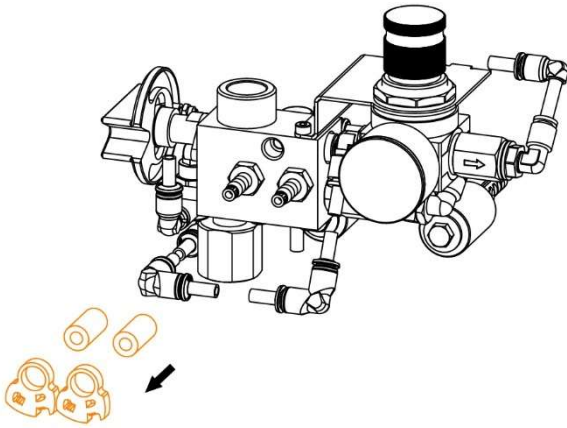

2. Remove the hose nipple.

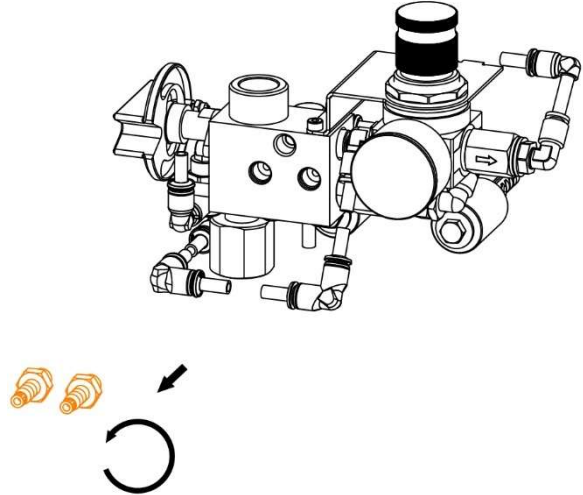

3. Fit all the O-rings, ball and spring.

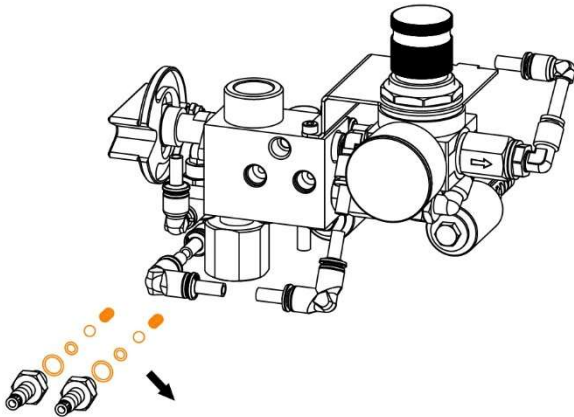

4. Fit the new O-rings, ball and spring.

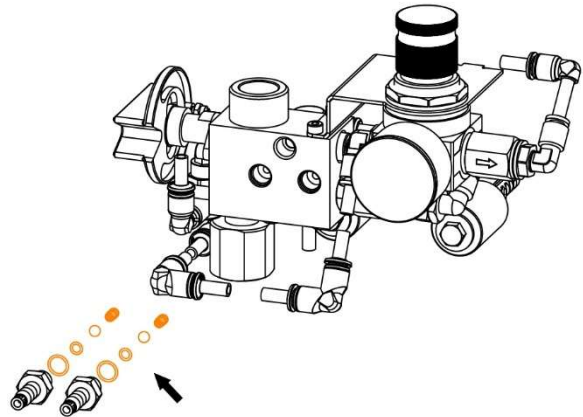

5. Fit the hose nipple.

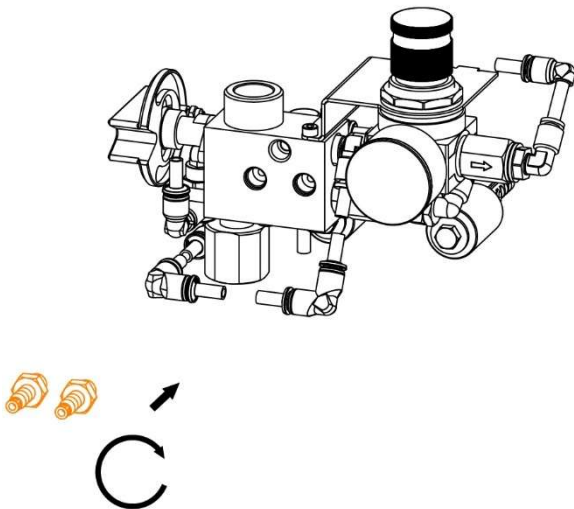

6. Fit the suction hose and hose clamp.

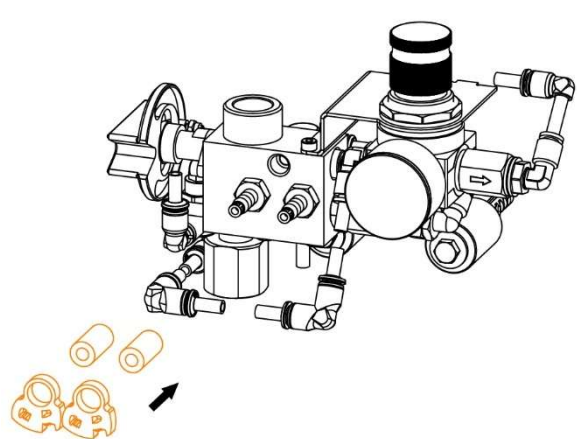

Chemical non-return valve, separate outlet

7. Remove the hose clamp and suction hose.

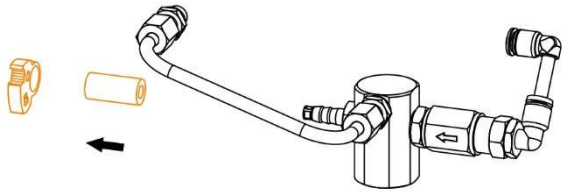

8. Remove the hose nipple.

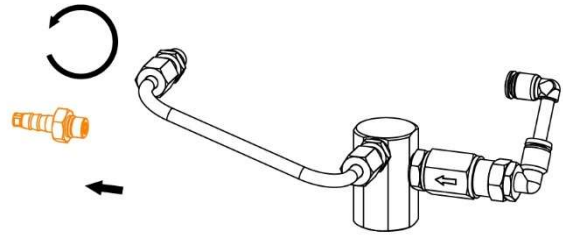

9. Fit all the O-rings, ball and spring.

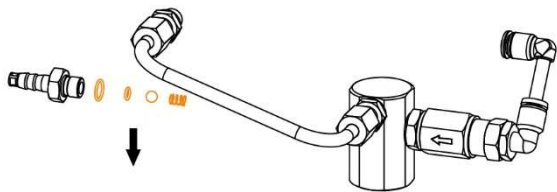

10. Fit the new O-rings, ball and spring.

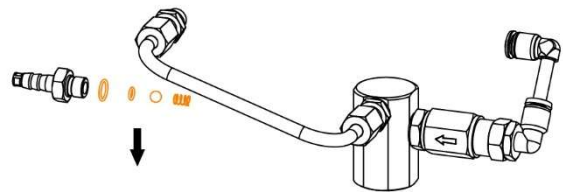

11. Fit the hose nipple.

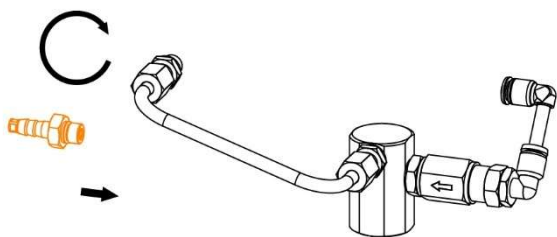

12. Fit the suction hose and hose clamp.

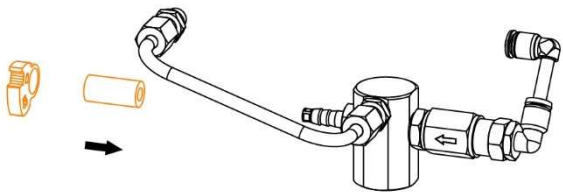

Non-return valve

1. Loosen the union nut around the non-return valve.

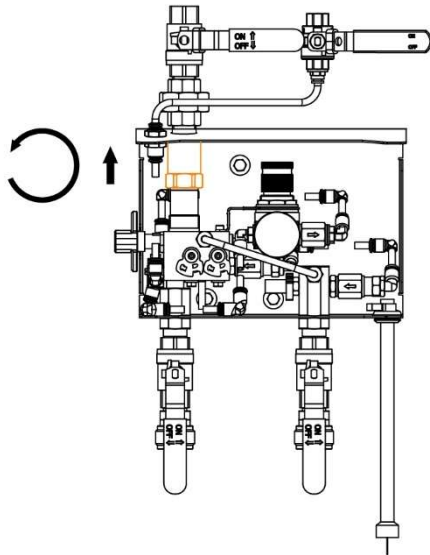

2. Remove the non-return valve.

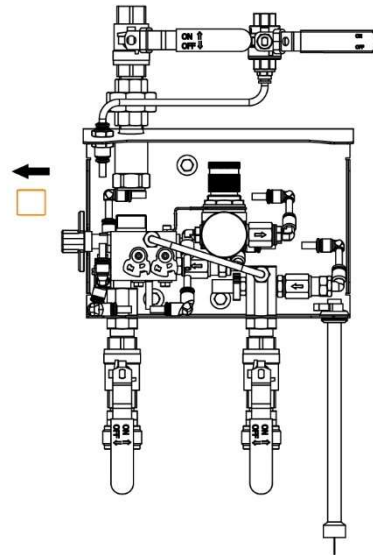

3. Remove the O-rings, spring and piston.

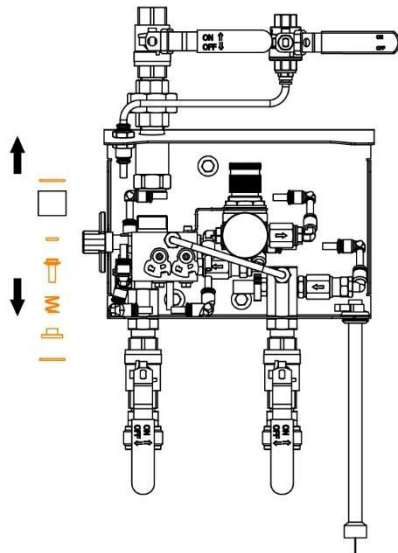

4. Fit the new O-rings, spring and piston.

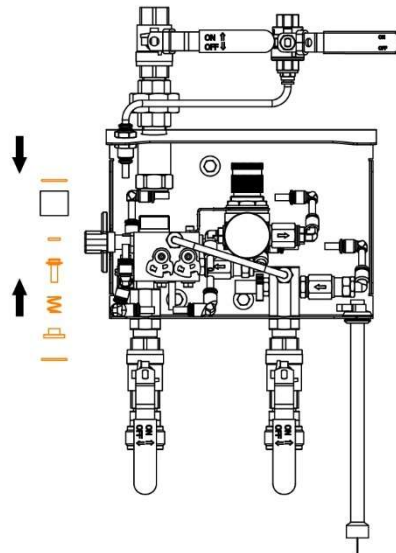

5. Fit the non-return valve.

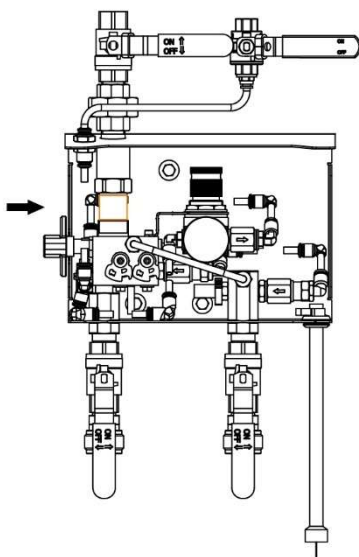

6. Tighten the union nut.

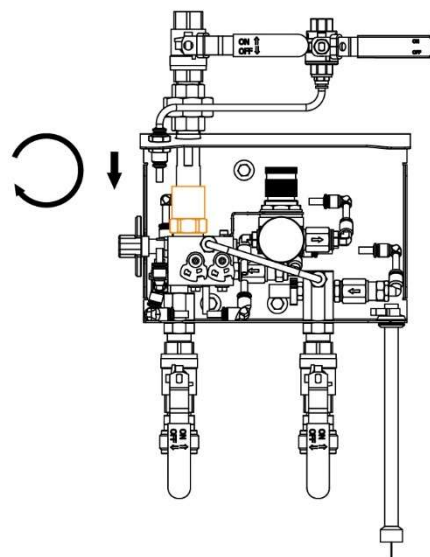

Replacing the O-rings, function selector axle.

1. Remove the air assembly.

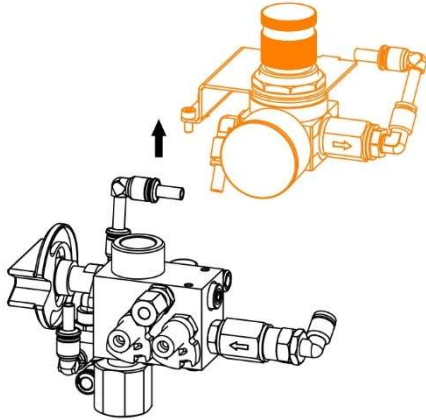

2. Remove the axle lock.

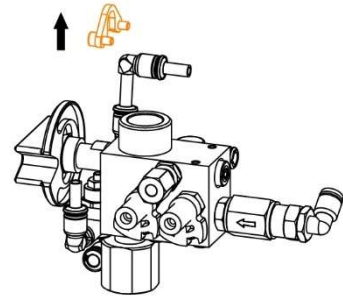

3. Remove the axle.

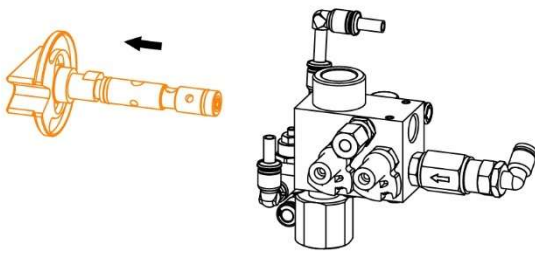

4. Remove the O-rings from the axle.

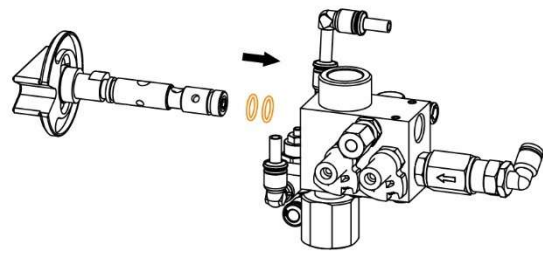

5. Fit the outer O-ring.

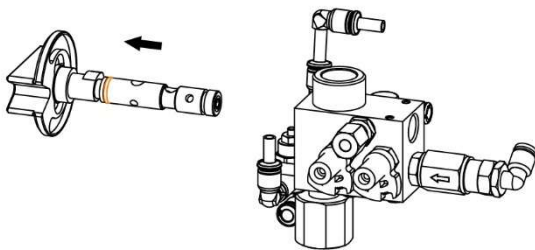

6. Fit the axle in the valve housing.

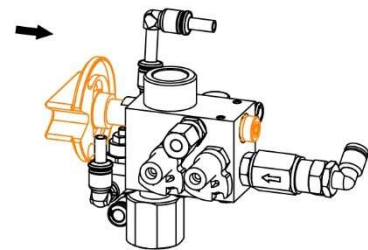

7. Fit the O-ring on the axle.

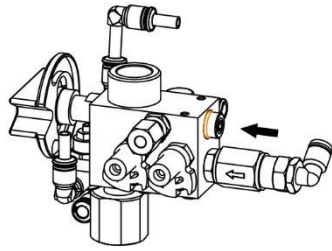

8. Pull the axle back slightly to make room for the axle lock.

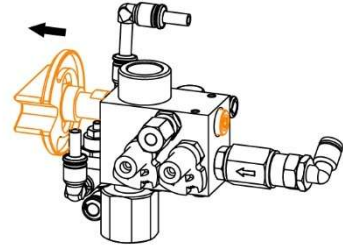

9. Fit the axle lock.

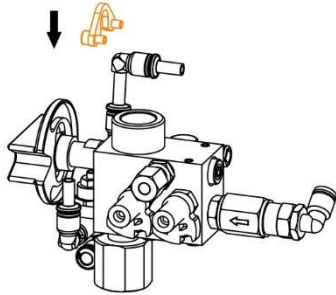

10. Fit the air assembly.

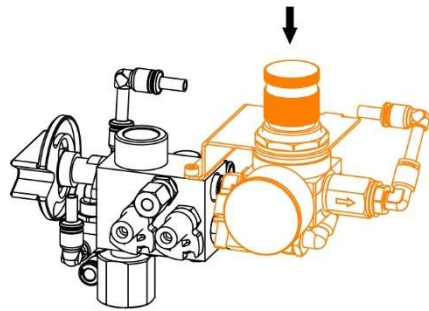

Inserting the valve after servicing.

1. Insert the valve assembly.

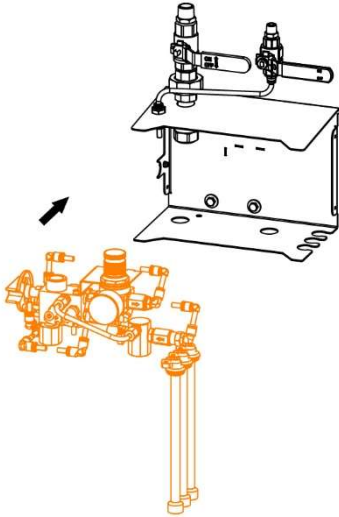

2. Fit the non-return valve.

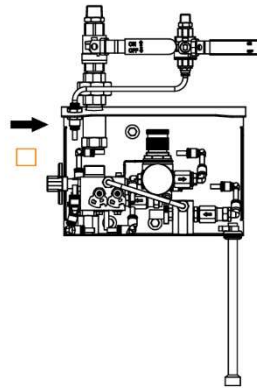

3. Tighten the union nut around the non-return valve.

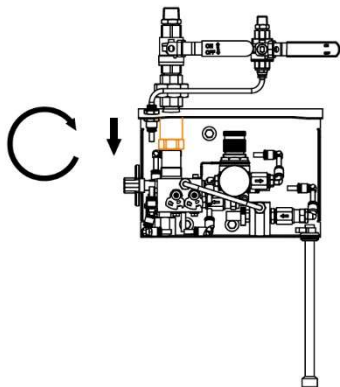

4. Fit the outlet valve.

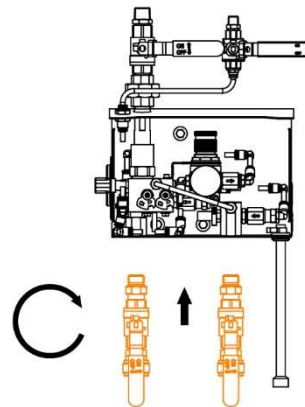

5. Fit the lid.

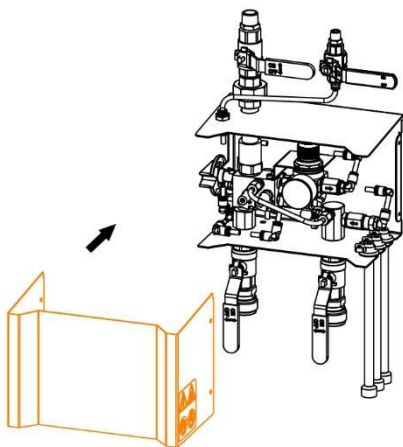

6. Tighten the screws in the side of the cabinet.

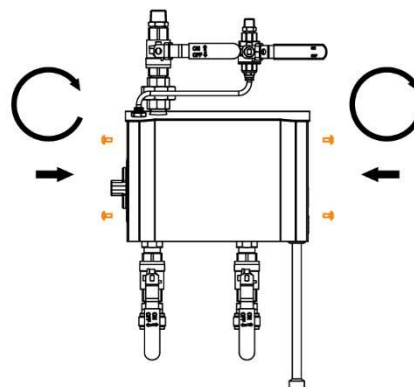

Restarting after servicing

1. Close the outlet valve.

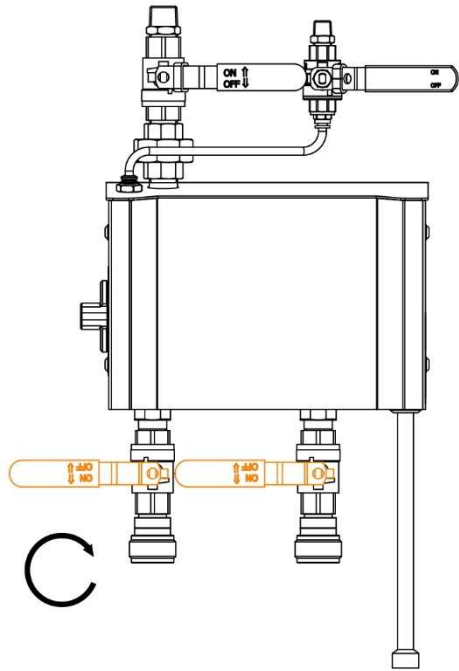

2. Open the inlet valves.

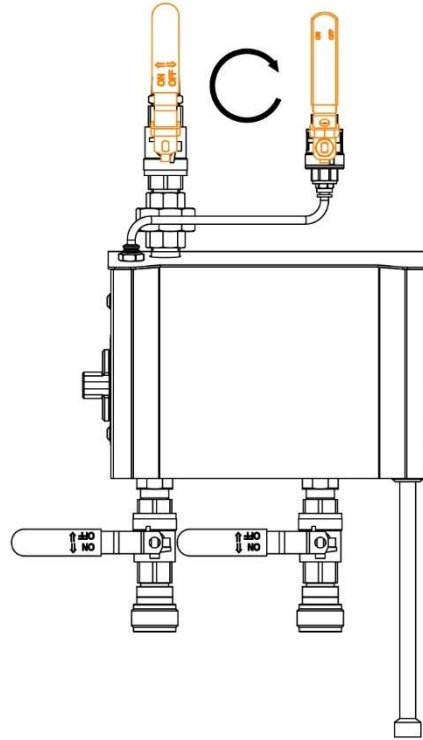

Quick operations guide

Adjusting the chemical concentration, main valve

1. Remove the hose clamp and suction hose.

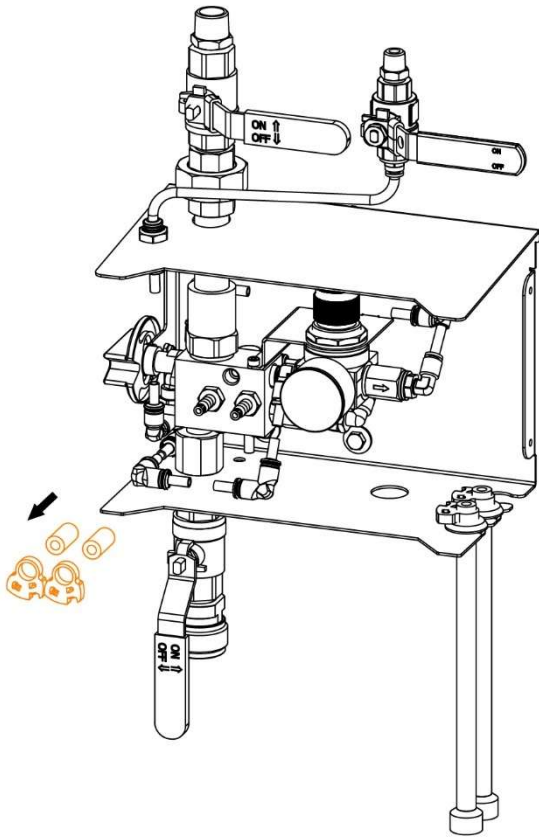

2. Remove the chemical limiter.

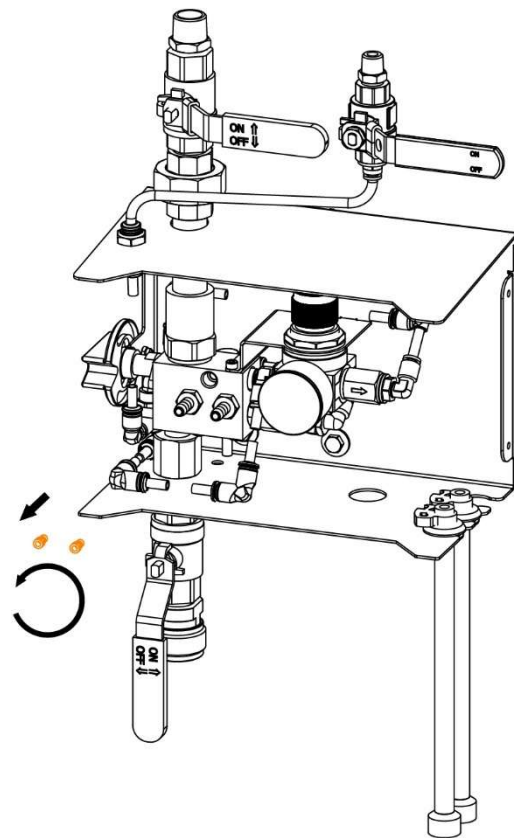

3. Fit the new chemical limiter.

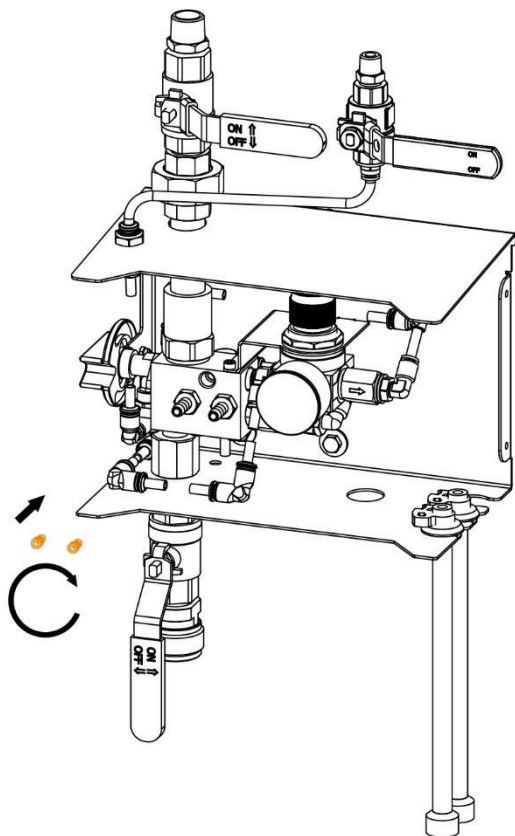

4. Fit the hose clamp and suction hose.

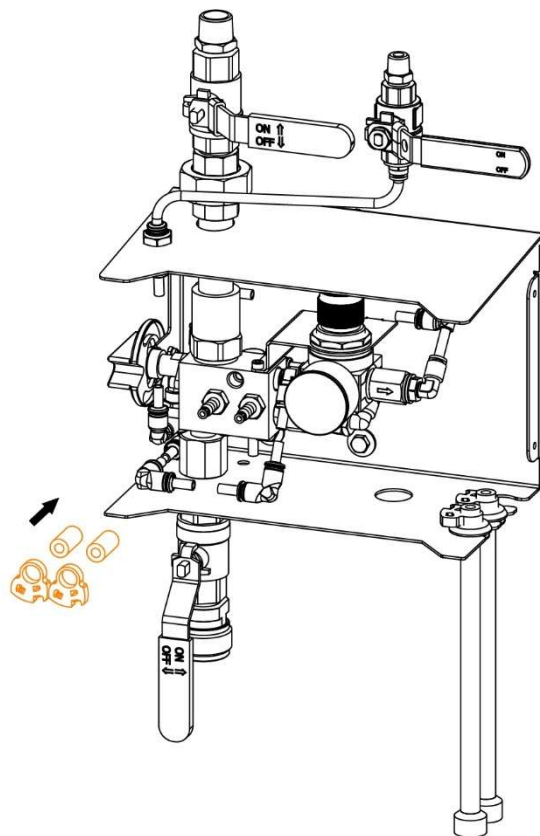

Adjust the chemical concentration, separate outlet

5. Remove the hose clamp and suction hose.

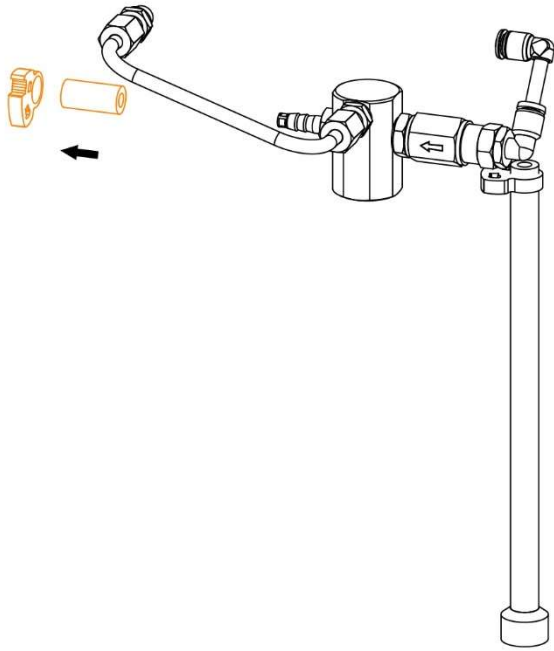

6. Remove the chemical limiter.

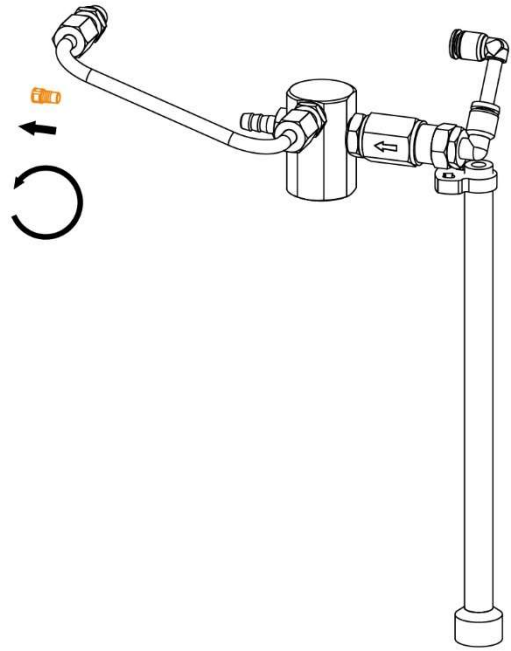

7. Fit the new chemical limiter.

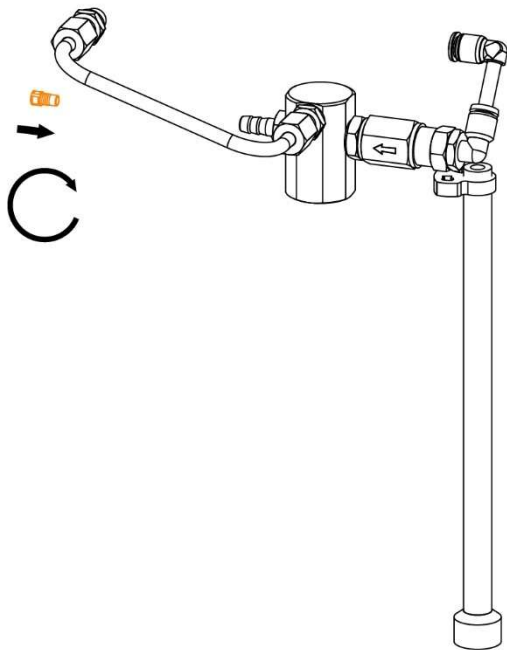

8. Fit the hose clamp and suction hose.

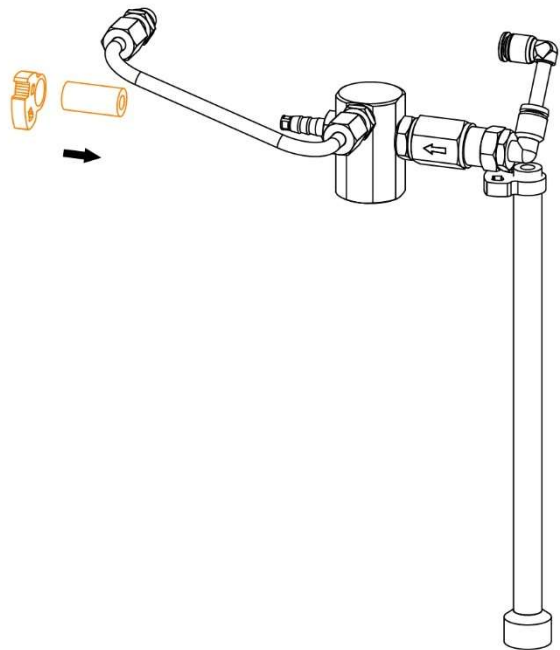

Concentration table

Dosing tip	15-25 bar Foam	3-8 bar Foam	15-25 bar Disinfection	3-8 bar Disinfection
Colour	Dosage (%) **	Dosage (%) **	Dosage (%) **	Dosage (%) **
Purple	0,7	0,7	0,7	0,7
Turquoise	1,4	1,6	1,4	1,6
Yellow	2,0	1,9	2,0	1,9
Brown	2,5	2,5	2,5*	2,5*
Orange	2,8	3,0	2,8	3,0
Green	3,6	3,6	3,6	3,6
Light brown*	5,4*	5,1*	5,4	5,1
Blue	7,2	5,9	7,2	5,9
White	8,1	6,7	8,1	6,7
Red	11,2	7,9	11,2	7,9
Beige	14,8	9,3	14,8	9,3
Black	16,7	10,0	16,7	10,0
Grey	17,0	10,2	17,0	10,2

* Fitted as standard

** Measured with water. The concentration depends on the water supply pressure, temperature, and the viscosity of the chemical

Adjustment of airflow/foam volume

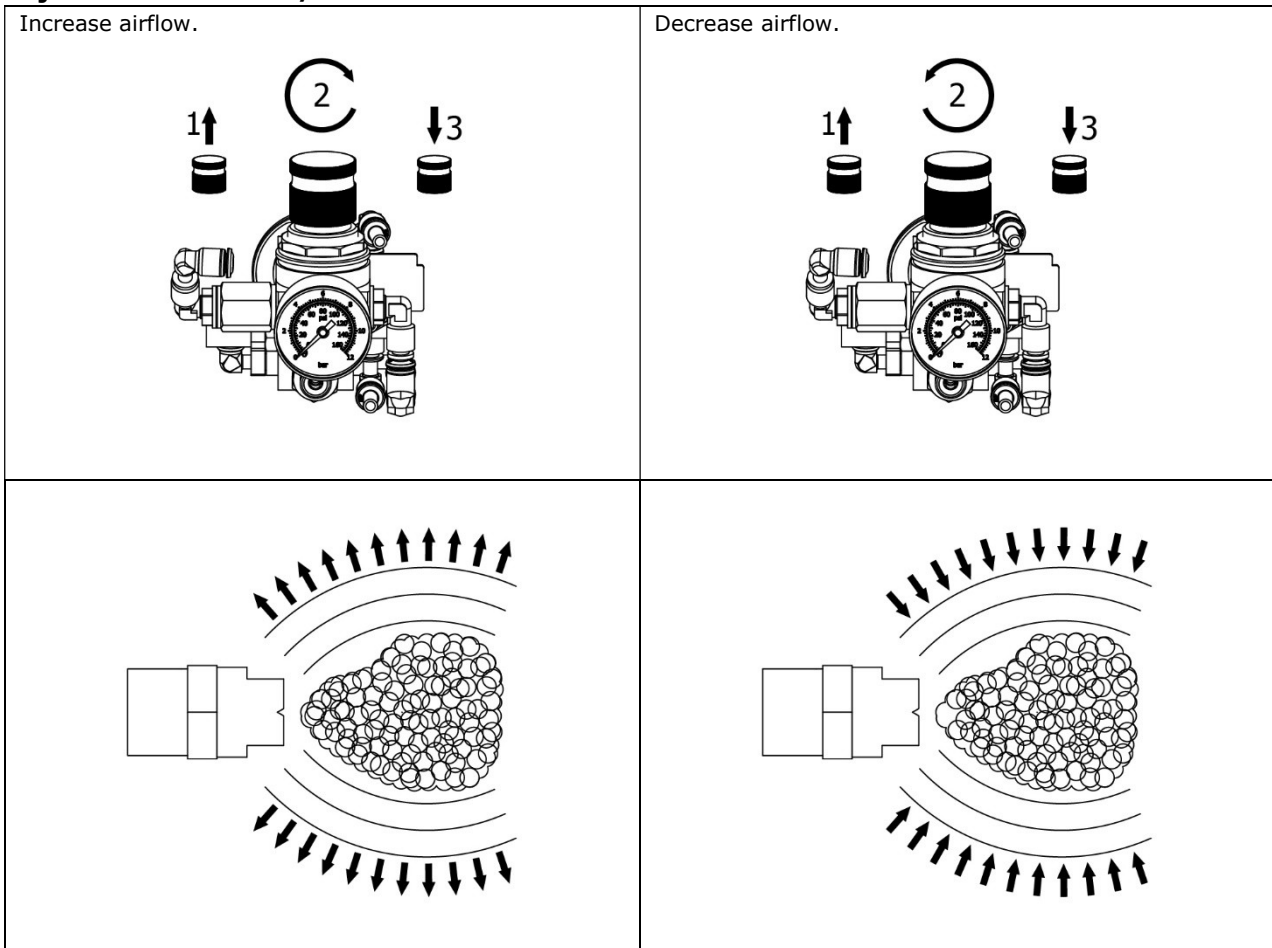

Mode F D

Step 1 - Pre-rinse.

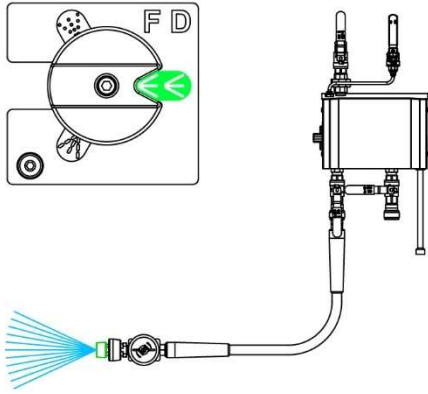

Step 2 - Foam application.

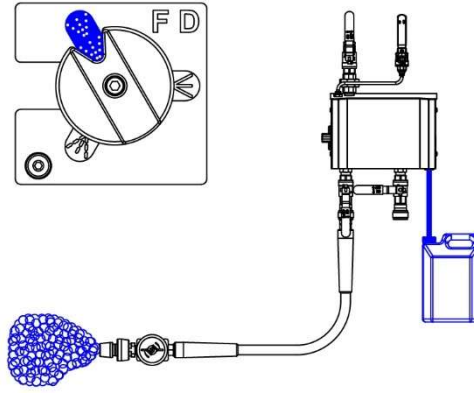

Step 3 - Rinse injector.

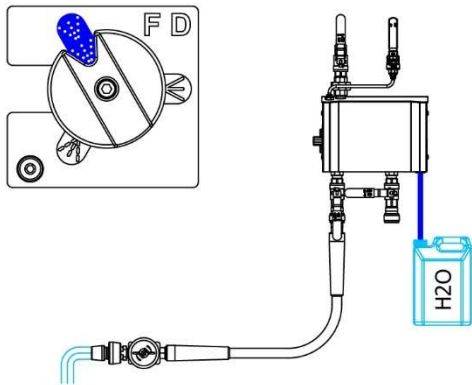

Step 4 - Rinse foam.

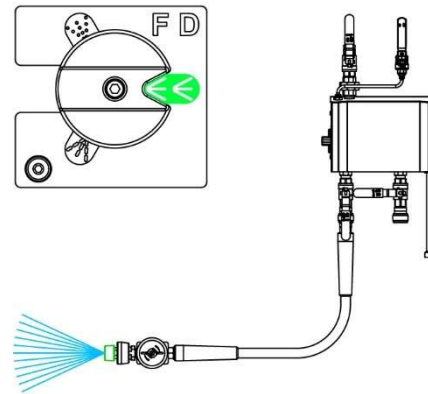

Step 5 - Disinfectant application.

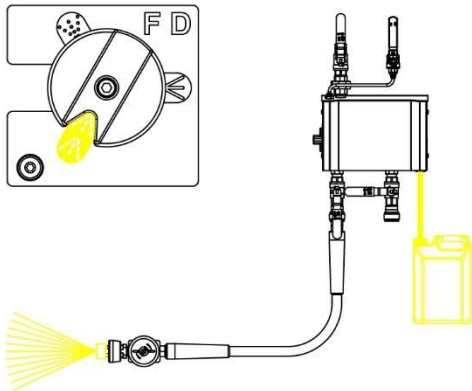

Step 6 - Rinse injector.

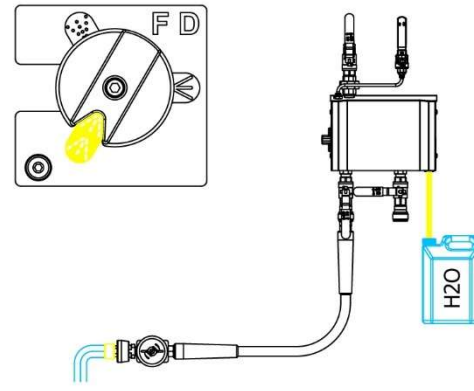

Step 7 - Rinse disinfectant fluid.

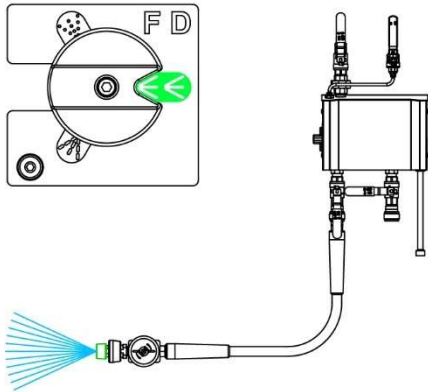

Step 8 - Close all inlet and outlet taps.

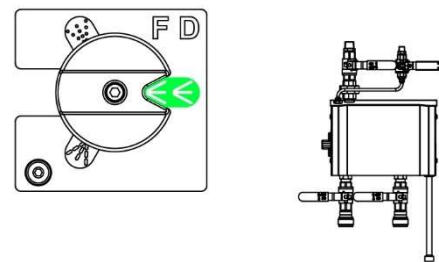

Mode F F

Step 1 - Pre-rinse.

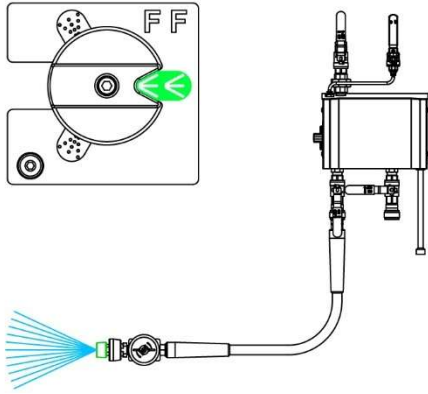

Step 2 - Foam 1 application.

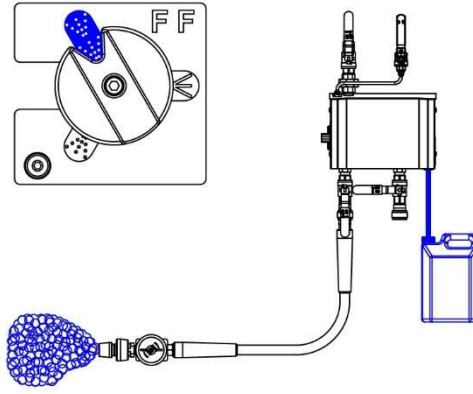

Step 3 - Rinse injector.

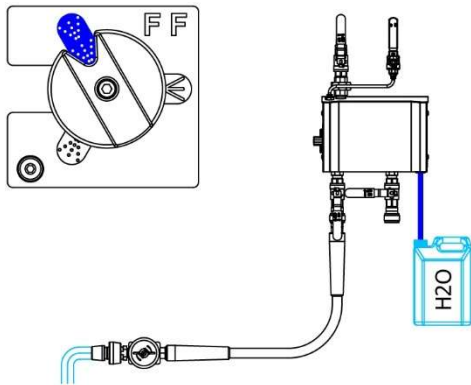

Step 4 - Rinse foam 1.

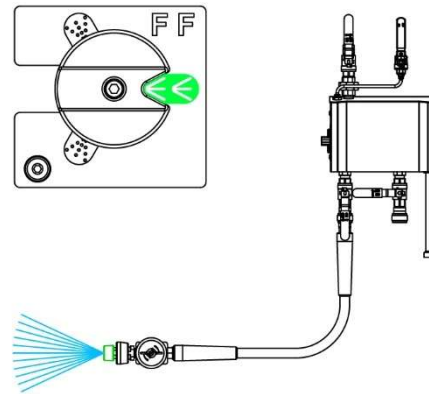

Step 5 - Foam 2 application.

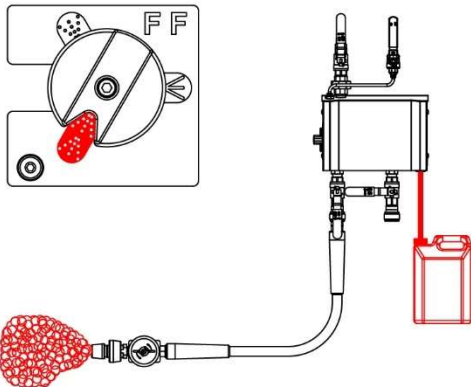

Step 6 - Rinse injector.

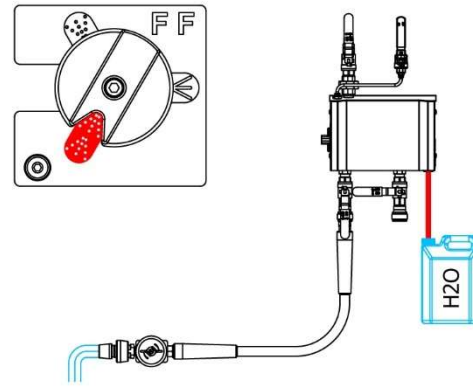

Step 7 - Rinse foam 2.

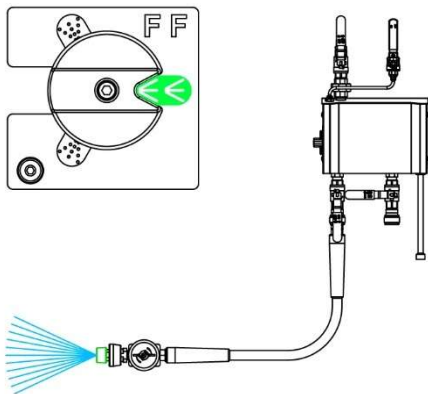

Step 8 - Close all inlet and outlet taps.

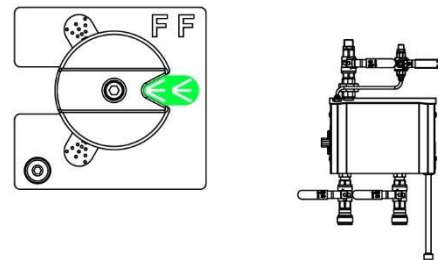

Mode separate D

Step 1 - Pre-rinse.

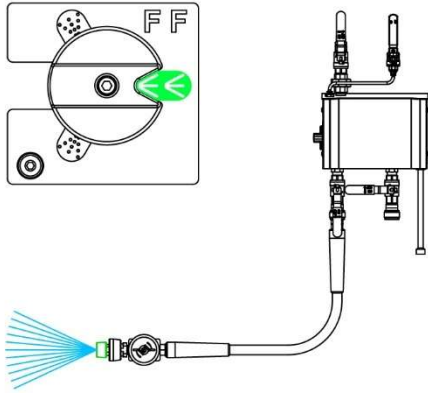

Step 2 - Disinfectant application.

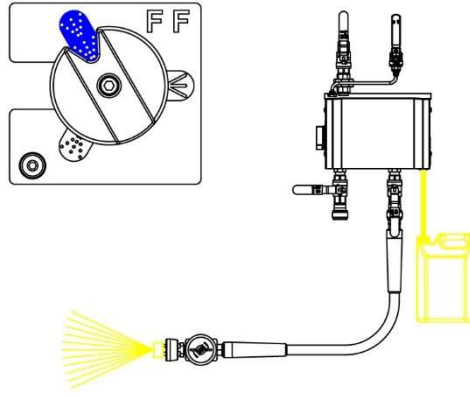

Step 3 - Rinse injector.

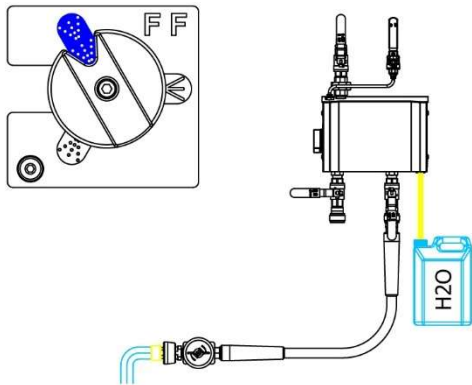

Step 4 - Rinse disinfectant fluid.

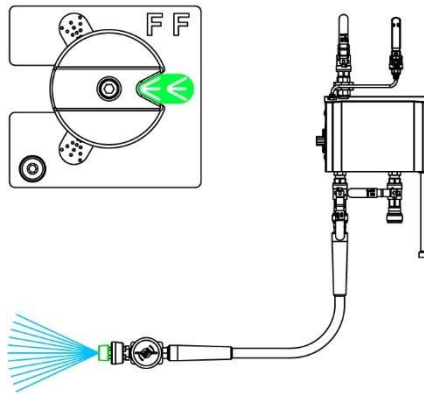

Step 5 - Close all inlet and outlet taps.

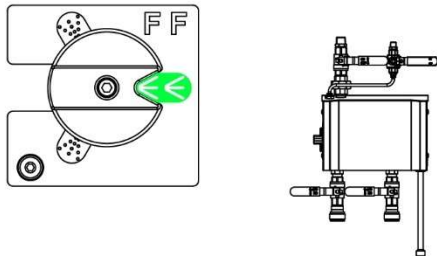

Mode separate F

Step 1 - Pre-rinse.

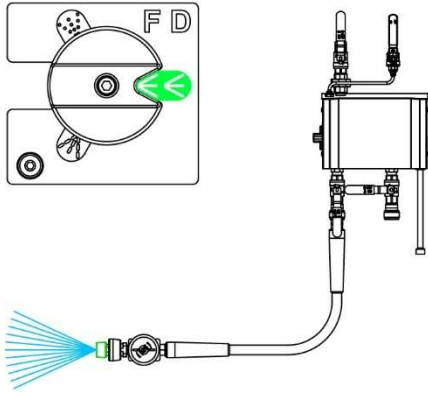

Step 2 - Foam application.

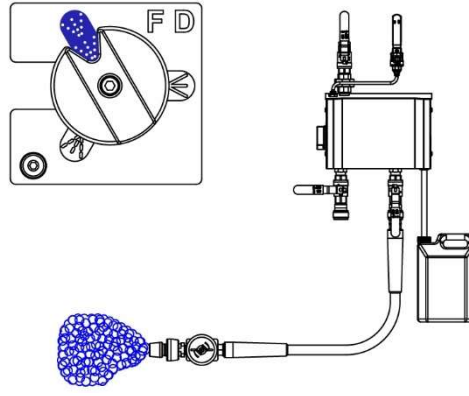

Step 3 - Rinse injector.

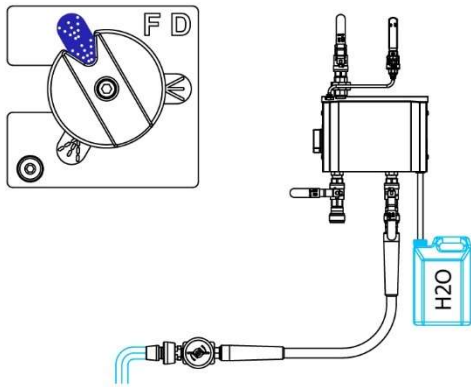

Step 4 - Rinse foam.

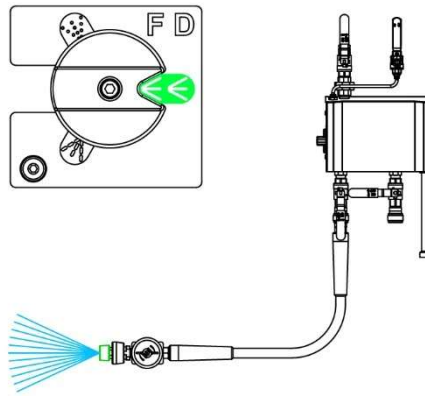

Step 5 - Close all inlet and outlet taps.

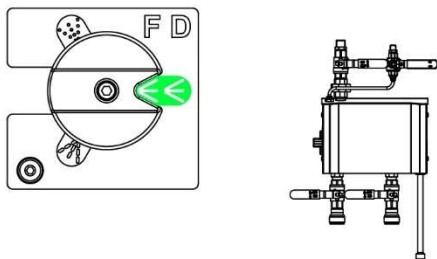

Flowdiagram
Mode F D & F F

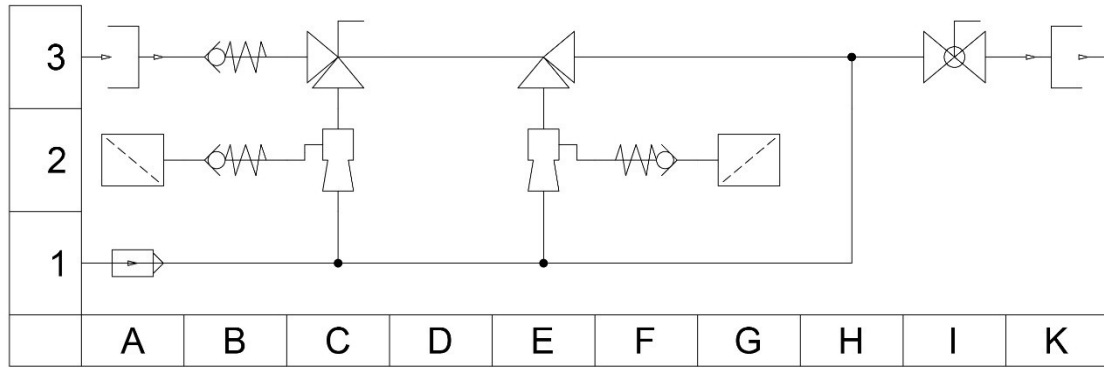

Row	Column	Description
1	A	Air nozzle
2	A	Chemical filter
2	B	Non-return valve, chemicals
2	C	Injector 1
2	E	Injector 2
2	F	Non-return valve, chemicals
2	G	Chemical filter
3	A	Water inlet
3	B	Non-return valve, water
3	C	Function selector valve
3	I	Valve, outlet
3	K	Outlet

Mode F D & F F + F or D

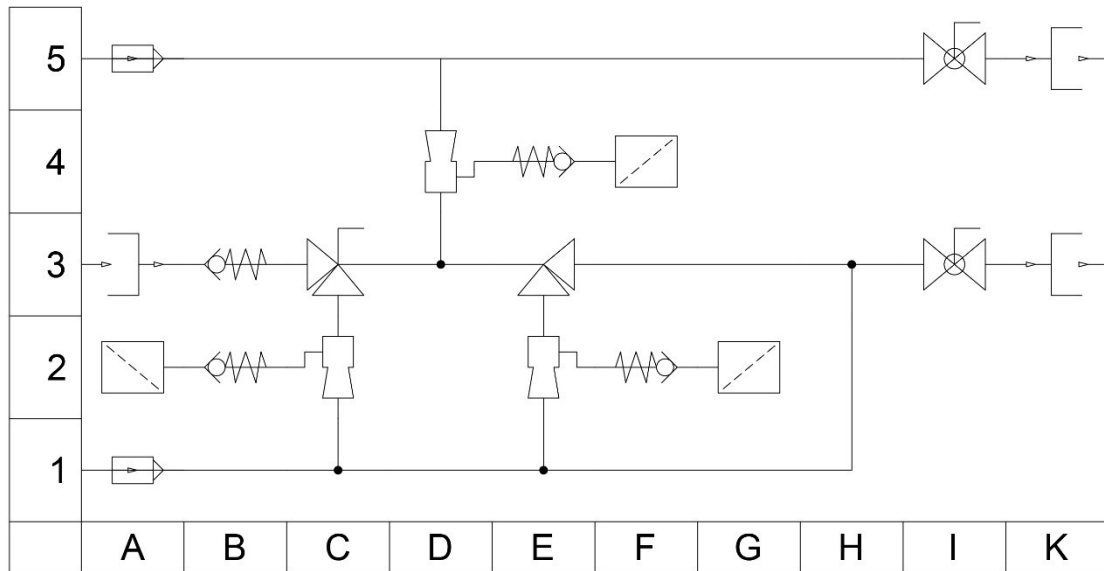

Row	Column	Description
1	A	Air nozzle
2	A	Chemical filter
2	B	Non-return valve, chemicals
2	C	Injector 1
2	E	Injector 2
2	F	Non-return valve, chemicals
2	G	Chemical filter
3	A	Water inlet
3	B	Non-return valve, water
3	C	Function selector valve
3	I	Valve, outlet
3	K	Outlet
4	D	Separate injector
4	E	Non-return valve, chemicals
4	F	Chemical filter
5	A	Air nozzle (F mode only)
5	I	Valve, outlet
5	K	Outlet

Troubleshooting

Error	Cause	Solution
No rinse pressure.	No water pressure.	Start the supply unit.
	The ball valve on top of the system is closed.	Open the valve.
	Wrong mode selected on function selector.	Select the correct mode.
	Deposits have accumulated in the water check valve.	Check the water non-return valve.
Poor foam quality.	Incorrect dosage.	Adjust the dosage in accordance with the chemical supplier's specifications.
	Suction filter or chemical restrictor blocked by chemical residues.	Clean the suction filter and chemical restrictor.
	Water pressure is too low.	Check the supply unit.
	Air pressure too low or too high.	Increase or decrease the air pressure.
The satellite unit does not suck up chemicals.	Suction filter or chemical restrictor blocked by chemical residues.	Clean the suction filter or chemical restrictor.
	Water pressure is too low.	Check the supply unit.
	Suction filter above liquid level in chemical container.	Bring the suction filter below liquid level.

Manual revision

Rev.	Description	Date	Ini.
A	Manual created	30-03-2026	jha

System Cleaners A/S

Halkjærvej 17
DK-9200 Aalborg SV
Denmark
Tel.: +45 96 34 04 04
info@systemcleaners.com
www.systemcleaners.com

Please note that:

We reserve the right to make changes to the technical specifications without notice.

Version A, EN.

S2 Evo

Page **44** of **44**